

CRYO TUNNEL- FP1

- Designed for hygiene & cleanability
- Increased productivity by up to 20%
- Easy to operate
- Push button/plc hybrid control panel

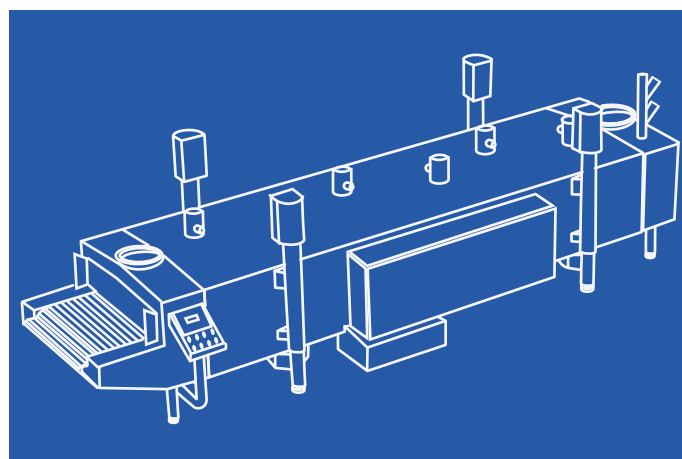

The Concept

The **CRYO TUNNEL- FP1** is a fully welded, stainless steel, in-line cryogenic tunnel with modular sections that can be easily integrated into any food processing line. The **CRYO TUNNEL-FP1** offers the versatility to efficiently freeze, crust freeze or chill nearly any type of food product using liquid nitrogen or carbon dioxide while ensuring exceptional product quality.

It is ideal for those processors that need increased productivity, excellent hygiene design plus ease of operation and maintenance, with a minimal capital investment and installation cost.

The **CRYO TUNNEL-FP1** is available in 3 freezing zone lengths and 3 belt widths, along with a higher product clearance in order to meet the specific productivity, space and installation requirements of the food processor.

Industries

The **CRYO TUNNEL- FP1** is ideal for freezing, crust freezing and chilling many types of food products in the following sectors:

- Meat
- Poultry
- Fish & Seafood
- Ready Meals
- Fruits & Vegetables
- Bakery
- Dairy
- Ice Cream

Features

The **CRYO TUNNEL- FP1** is constructed with stainless steel food contact surfaces and a fully welded stainless steel insulated body. The hygienically-designed lifting system ensures that the lid can open completely for better accessibility during cleaning, sanitation and maintenance functions. The inside corners are curved while the base of the freezer has a sloped floor with drain openings for better drainage of the wash water and cleaning solutions during the cleaning operation.

The **CRYO TUNNEL-FP1** uses proprietary hygienic, stainless steel, high performance fan blades to ensure optimal heat transfer, cryogen efficiency and consistency of freezing.

The cryogen injection system consists of a hygienically-designed manifold which operates on either liquid nitrogen or carbon dioxide and automatically adjusts to meet the changing product heat load requirements using specially-designed software.

The **CRYO TUNNEL-FP1** is simple to operate with its push button/PLC hybrid control panel and delivers excellent performance with respect to quality, cryogen efficiency and productivity throughput.

Benefits

- Flexibility to freeze, crust freeze or chill different types of food products
- Higher product clearance to accommodate larger food products
- Wider range of dwell times
- Increased productivity by up to 20%
- Excellent cryogen efficiency with savings of up to 10%
- New hygiene features to eliminate food safety hazards
- Compact design which requires minimal floor space
- Safe and easy to install and operate
- Low maintenance costs
- Fast and easy to clean

Model Range

The CRYO TUNNEL- FP1 range includes the following sizes:

60 x 6	90 x 6	120 x 6
60 x 9	90 x 9	120 x 9
60 x 12	90 x 12	120 x 12

The CRYO TUNNEL- FP1 meets the required standards & regulations for the following locations:

- Europe
- Middle East
- Africa
- Asia
- Pacific
- South America

Technical Data

	60 x 6	90 x 6	120 x 6
Overall Dimensions (m)			
Length	7.8	10.5	13.3
Width	1.9	1.9	1.9
Height	2.4	2.4	2.4
Height in Cleaning Position	3.0	3.0	3.0
Freezing Chamber (m)			
Length	5.5	8.3	11.0
Usable Width	0.6	0.6	0.6
Product Clearance	0.2	0.2	0.2
Usable surface (m ²)	3.3	5.0	6.6
Tunnel Weight (kg)	3400	4500	5500
Height of the Loading Zone (m)	0.9	0.9	0.9
Power Supply	400V, 50 Hz, 3 phase + PE		
Electrical Power (kW)	18.6	21.9	25.2

	60 x 9	90 x 9	120 x 9
Overall Dimensions (m)			
Length	7.8	10.5	13.3
Width	2.2	2.2	2.2
Height	2.4	2.4	2.4
Height in Cleaning Position	3.0	3.0	3.0
Freezing Chamber (m)			
Length	5.5	8.3	11.0
Usable Width	0.9	0.9	0.9
Product Clearance	0.2	0.2	0.2
Usable surface (m ²)	5.0	7.5	9.9
Tunnel Weight (kg)	3700	4700	6500
Height of the Loading Zone (m)	0.9	0.9	0.9
Power Supply	400V, 50 Hz, 3 phase + PE		
Electrical Power (kW)	18.6	21.9	25.2

	60 x 12	90 x 12	120 x 12
Overall Dimensions (m)			
Length	7.8	10.5	13.3
Width	2.5	2.5	2.5
Height	2.4	2.4	2.4
Height in Cleaning Position	3.0	3.0	3.0
Freezing Chamber (m)			
Length	5.5	8.3	11.0
Usable Width	1.2	1.2	1.2
Product Clearance	0.2	0.2	0.2
Usable surface (m ²)	6.6	10.0	13.2
Tunnel Weight (kg)	4000	5000	7000
Height of the Loading Zone (m)	0.9	0.9	0.9
Power Supply	400V, 50 Hz, 3 phase + PE		
Electrical Power (kW)	18.6	21.9	25.2

Options

- Variable Speed Control for Fan Motors
- Variable Speed Control for Exhaust Fan
- Spare Parts Kit
- Other belt mesh sizes

Installation Layout

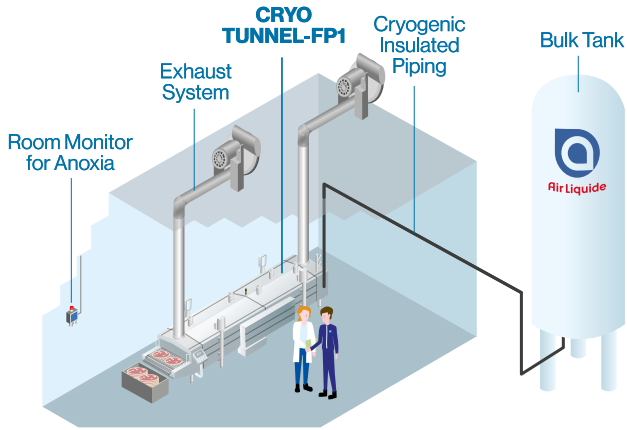

Related Offer

The **CRYO TUNNEL- FP1** is a part of the **Nexelia for Freezing & Chilling** offer which has been specifically designed for those processors that need to achieve a competitive freezing or chilling cost for their food products. The Nexelia solution includes the best of Air Liquide's ALIGAL™ food grade gases, state-of-the-art application equipment and technical support services along with a customized cryogen consumption monitoring program.

Contact us

Air Liquide Standard Application Equipment - France
Phone : +33 139 07 62 55
E-mail : application.equipment@airliquide.com

www.airliquide.com

