

LINE SÄÄNTELYVIRANOMAISTEN DCN300 AG 50-6-150 FOOD



- Line säädin - Yksiportainen
- Asennus putkiston
- Soveltuu ALIGAL kaasujen
- Valmistettu nikkelistä messinkiä

ruoka

Domains of applications

Designed for implementation of:

Kaasujen ALIGAL™ alue

Specifications

Maximal inlet pressure at 15°C..... 50 bar

Nominal nitrogen flow 150 Nm³/h*

Käyttölämpötila: -20 °C + 50 °C: ssa.

* Nimellinen typen virtauksen 15 °C: ssa.

Materials

Body	Nikkelipronssista
Seat	Messinki
Main valve.....	Messinki EPDM päällystää
Diaphragm	PA-FKM, EPDM
Filter	Monel®
	Kupari metalliseos mekanismi, Ø
Pressure gauge	50mm
Seal	Kupari, EPDM

Monel® on tavaramerkki Special Metals Oy.

Highlights

Osa uutta Food-sarjaa

Dimensions

Length (L) : 67 mm
Height (H) : 134 mm
Depth (D) : 102 mm
Ø1 : 50 mm
Net weight : 1.2 kg

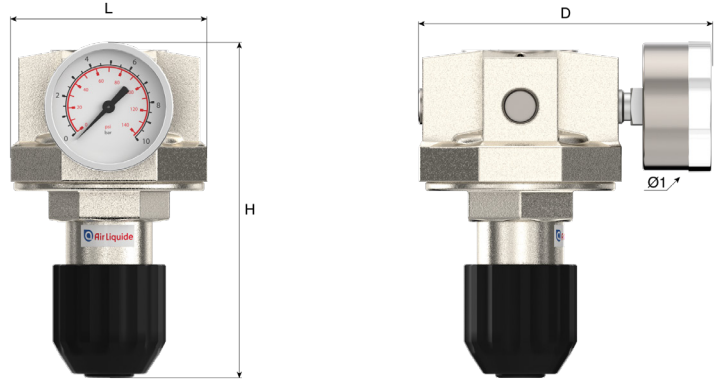

Operating instructions

OP 212 - DCn300

Connection

Inlet connection: 1 tuloaukon G 1/2" naaras
Outlet connection: 1 poistoaukon G 1/2" naaras

Flow curve

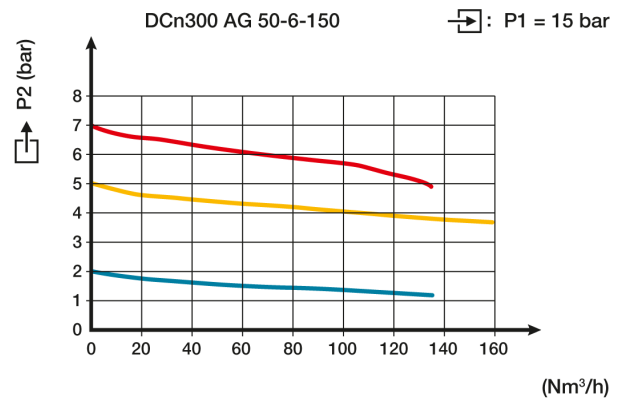

Products

Product Number	Short Designation	Gas	Inlet Pressure	Outlet Pressure	Flow	Inlet Fitting	Outlet Fitting	Material
193966	REG DCN300 AG 50-6-150 FOOD	ilma, CO2, inertti-kaasuja, H2, O2	50 bar	6 bar	150 Nm³/h	G 1/2 F	G puoli BSPP naaras	Messinki